

AVP-400 (new 2013)

PHOTOELECTRIC SMOKE DETECTORS

Item: 4706_400

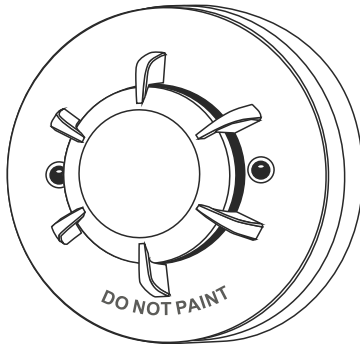

PRODUCT INTRODUCTION

AVP-400 Photoelectric smoke detector (hereinafter called detector) detects the smoke by a couple of infrared diodes. The principle of detecting is granule in the smoke can reflect infrared light. Infrared diodes are placed in the special chamber. The chamber can shield external light, but doesn't affect the smoke into it. While there is no smoke, the diode can receive very weak infrared light. When the smoke entering the chamber, diode can receive more and more light, and the detector can give out alarm signal when the smoke attains the certain density. In order to reduce the interference and lower power consumption, the emitting circuit adopts the pulse signal. The product in accordance with the networking approach is divided into 2- wire and 4-wire detectors.

TECHNICAL SPECIFICATION

PRODUCT CATEGORY	2 wire	4 wire
OPERATING VOLTAGE	DC 10V~30V	
STANDBY CURRENT	20uA	4mA(relay N.O.) 13mA(relay N.C.)
ALARM CURRENT	35mA@DC12V 83mA@DC 24V	19mA(relay N.O.) 9mA(relay N.C.)
ALARM INDICATION	RED LED ON	
TEMPERATURE RANGE	-10 ~ +50	
HUMIDITY	0%~95 % RH(NO CONDENSATION)	
ALARM OUTPUT	REMOTE LED	RELAY OUTPUT
CONTACT RATING	N/A	0.1A@DC28V
STANDARD	EN54-7/UL268	
DIMENSION	100 mm diameter*48mm deep	

CONNECTION DESCRIPTION

- 2 wire smoke detectors :base terminals "1" and "2" for DC power input. "1" for DC power positive pole or cathode input, "2" for DC power positive pole or cathode output. "3" for remote indicator cathode. When remote indicator is used "1" in must be connected to the positive line in .
- 4 wire smoke detectors : base terminals "1" and "2" for DC power input. "3" for relay output com, "4" for relay output N.C. or N.O.

PRODUCT FEATURES

- STRONG ADAPTABILITY FOR CIRCUMSTANCE
- SMT ELECTRONICS, HIGH STABILITY
- 10-30VDC WIDE VOLTAGE OPERATING RANGE
- LOW STANDBY CURRENT
- TWIN LED FOR 360 °VISUAL
- FLASHING LED POWER INDICATOR
- REMOTE LED INDICATOR OUTPUT(2-WIRE)
- METAL SHIELD PROTECTS EMI & RFI INTERFERENCE

WIRING DIAGRAM

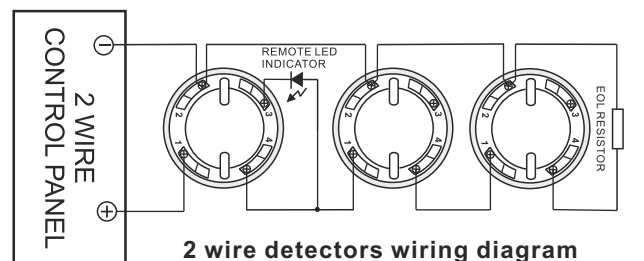

- 1 POWER(+)IN
- 2 POWER(-)
- 3 REMOTE LED(-)
- 4 POWER(+)/OUT

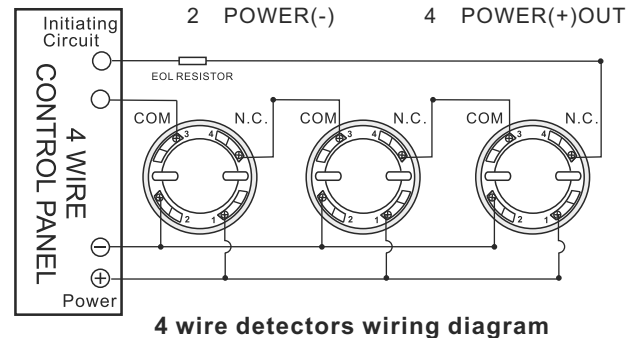

- 1 ANODE INPUT
- 2 CATHODE INPUT
- 3 RELAY OUTPUT(COM)
- 4 RELAY OUTPUT(N.C)

NOTICE

- The detector can not be installed under worse environment. E.g. coldest, hottest, dusty, do not remove the dustproof cover until use the detector indeed.
- Make sure that there is no block within 0.5m from detector.
- Keep the distance between detector and wall more than 0.5m.
- Make sure the distance between detectors be less than 15m. And the distance between detector and corner must be less than half of the one between detectors.
- Horizontally install the detector. If have to be installed slantingly, please keep the angle less than 45 degrees)
- Detectors base be installed solid , wire connections must be reliable.
- Recommendations should be carried out every six months a simulated fire test, the test detectors are working properly.
- For various reason, including, but not limited to changes in environmental conditions, electric disruptions and tampering, the product may not perform as expected. The user is advised to take all necessary precautions for his/her safety and the protection of his/her property.